

CNDX-01 FEATURES

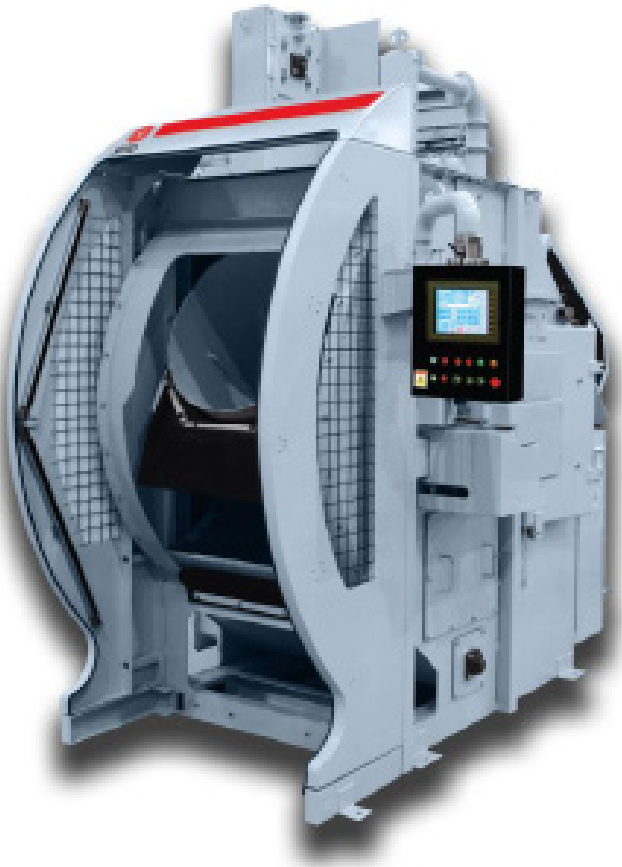

- | Consistent and highly efficient finishing
- | Drum rocks while processing, reducing cycle time over conventional drum styles
- | Energy saving- reduced cycle time
- | No leak design reduces maintenance and minimizes downtime
- | Smooth, reliable loading with hydraulic loader
- | No jamming of parts or belt tearing issues as with rubber belt machines

DRUM BLAST MACHINE

DUCT WORK INCLUDES
ANTI-STATIC GROUNDING



100% MANGANESE
PROCESS DRUM



IDEAL FOR SMALL TO
MEDIUM SIZE PARTS



CNDX-01

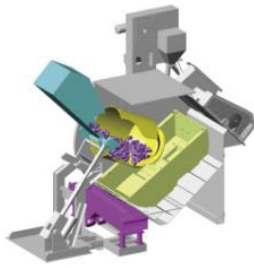

LOADING

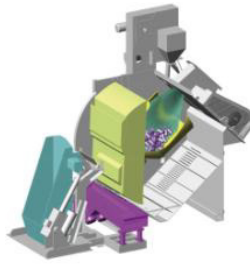

BLASTING

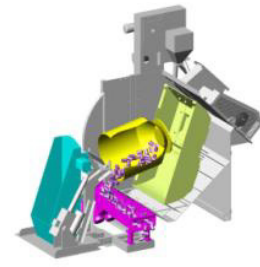

DISCHARGING

DIMENSIONS

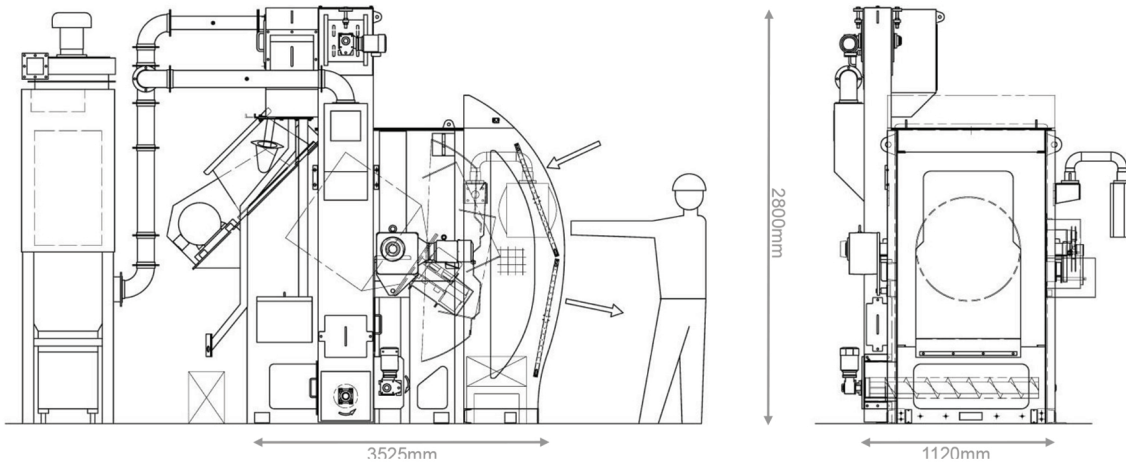

SPECIFICATIONS

Machine Description	CNDX-01
Capacity	
Blasting capacity	2-3 ft ³ / batch
Loading weight (max)	331 lb/batch (150 kg/batch)
Weight per workpiece (max)	22 lb/piece (10 kg/piece)
Size of workpiece (max)	Dia 6" x L 8" (Dia 150mm x L 200mm)
Impeller	
Model	Y30
Motor capacity (1 unit)	7.5kW (10 hp)
Dust Collector	
Air Volume	354 ft ³ / min (10 m ³ / min)



SINTO AMERICA, INC.

SINTOKOGIO GROUP
 3001 W. Main Street, PO Box 40760
 Lansing, MI 48901
 Tel: 517 371 2460 Fax: 517 371 4930
 Web: www.sintoamerica.com Email: sales@sintoamerica.com

